

North Sea Super Wind Power Grid

Dr Norman MacLeod
Technical Marketing Director
June 2011

GRID |

ALSTOM

Contents

How will the Super Grid Evolve?

DC Grid Control

DC Grid Protection

European Super Grid - concept

Inter-connectors
Off-shore Wind farms

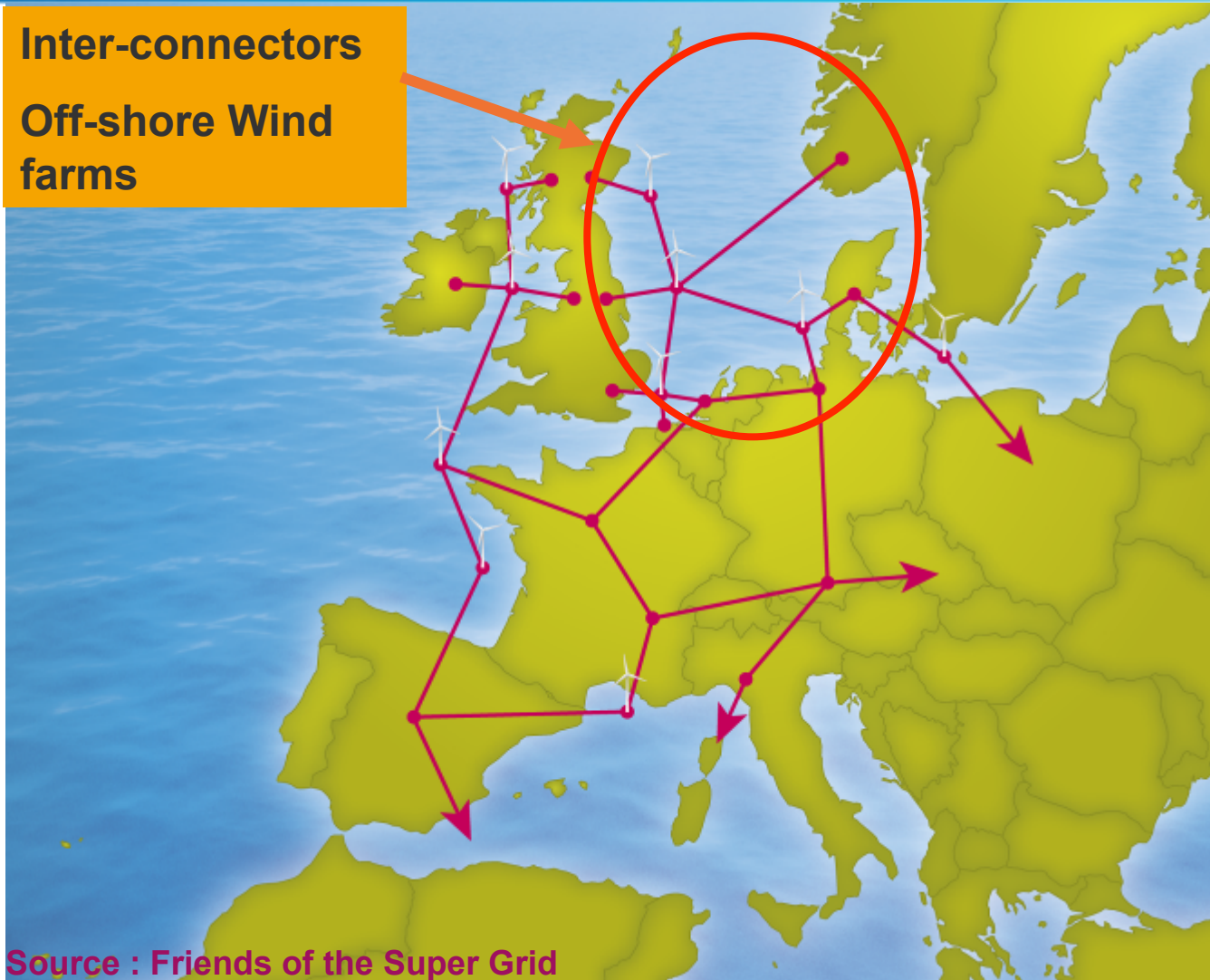

Source : Friends of the Super Grid

HVDC Connections - incl. Off-shore Wind Farms

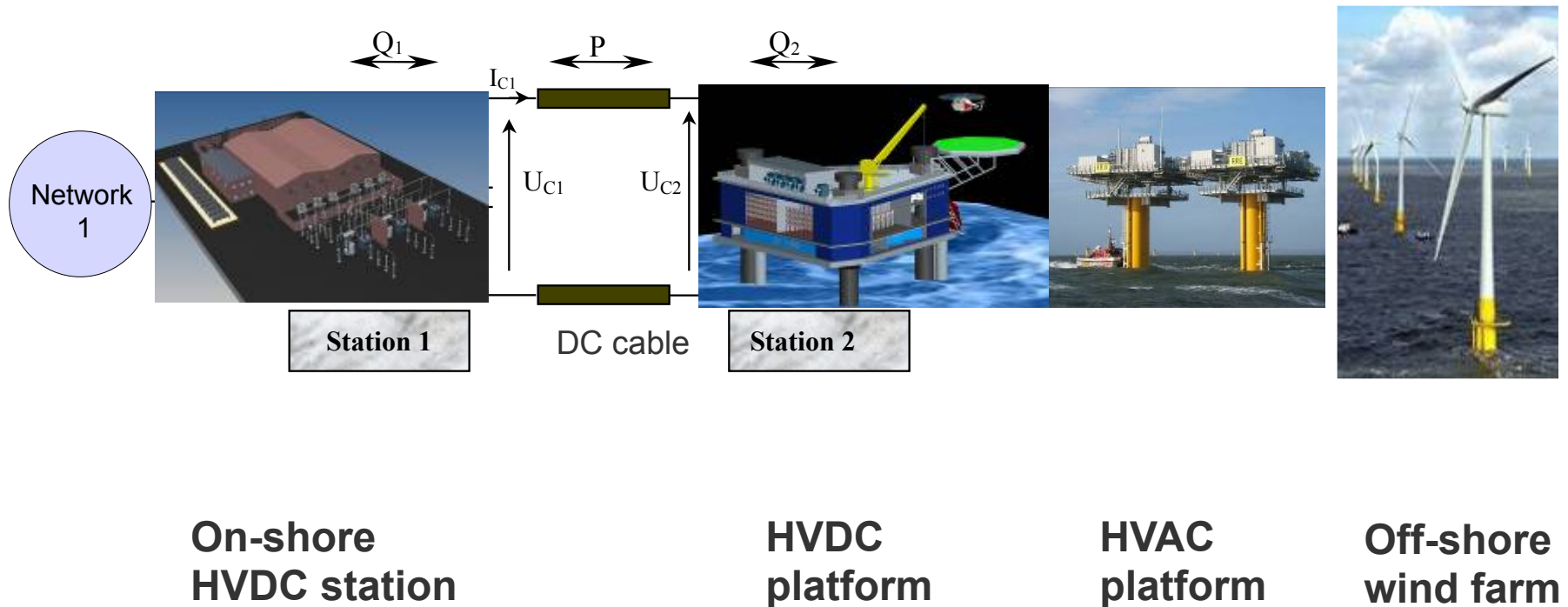

First 400MW Off-shore HVDC station now in commissioning trials - Tennet (Germany)

Borwin Alpha – ABB (HVDC), Bard (Off-shore Project), Siemens (WTG)

Radial DC Connection

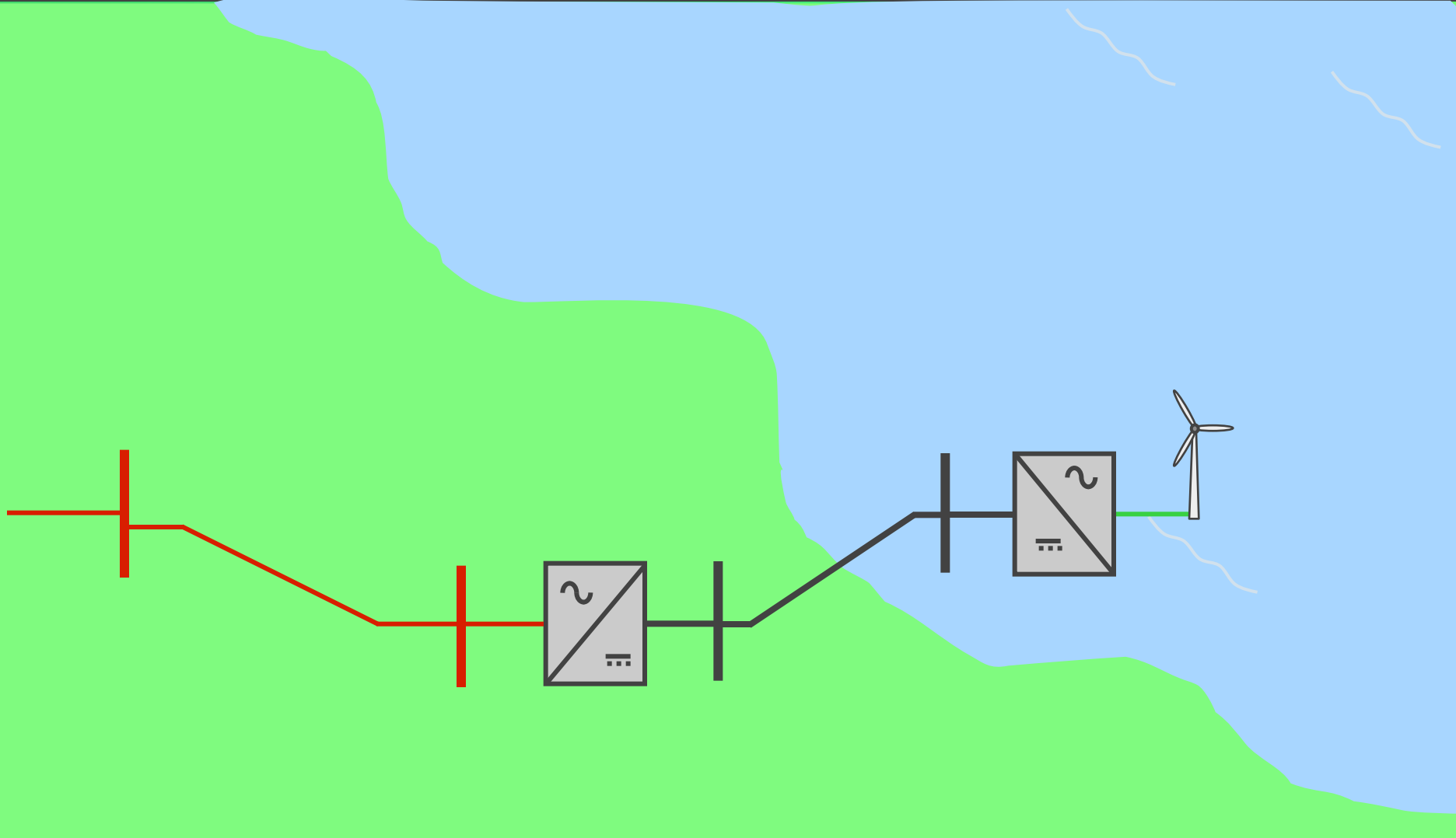

Radial DC Connections

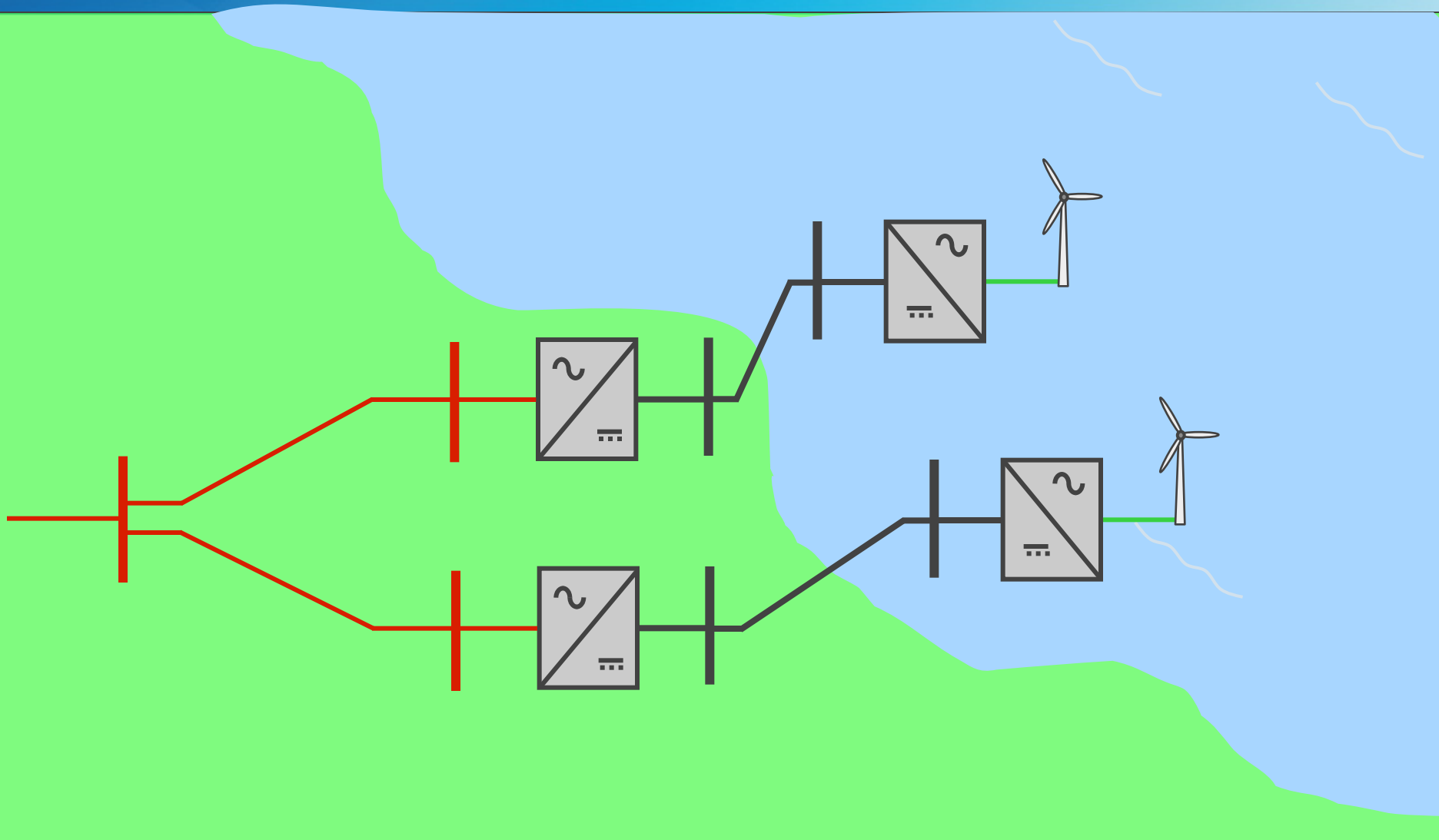

Multiple Radial DC Connections

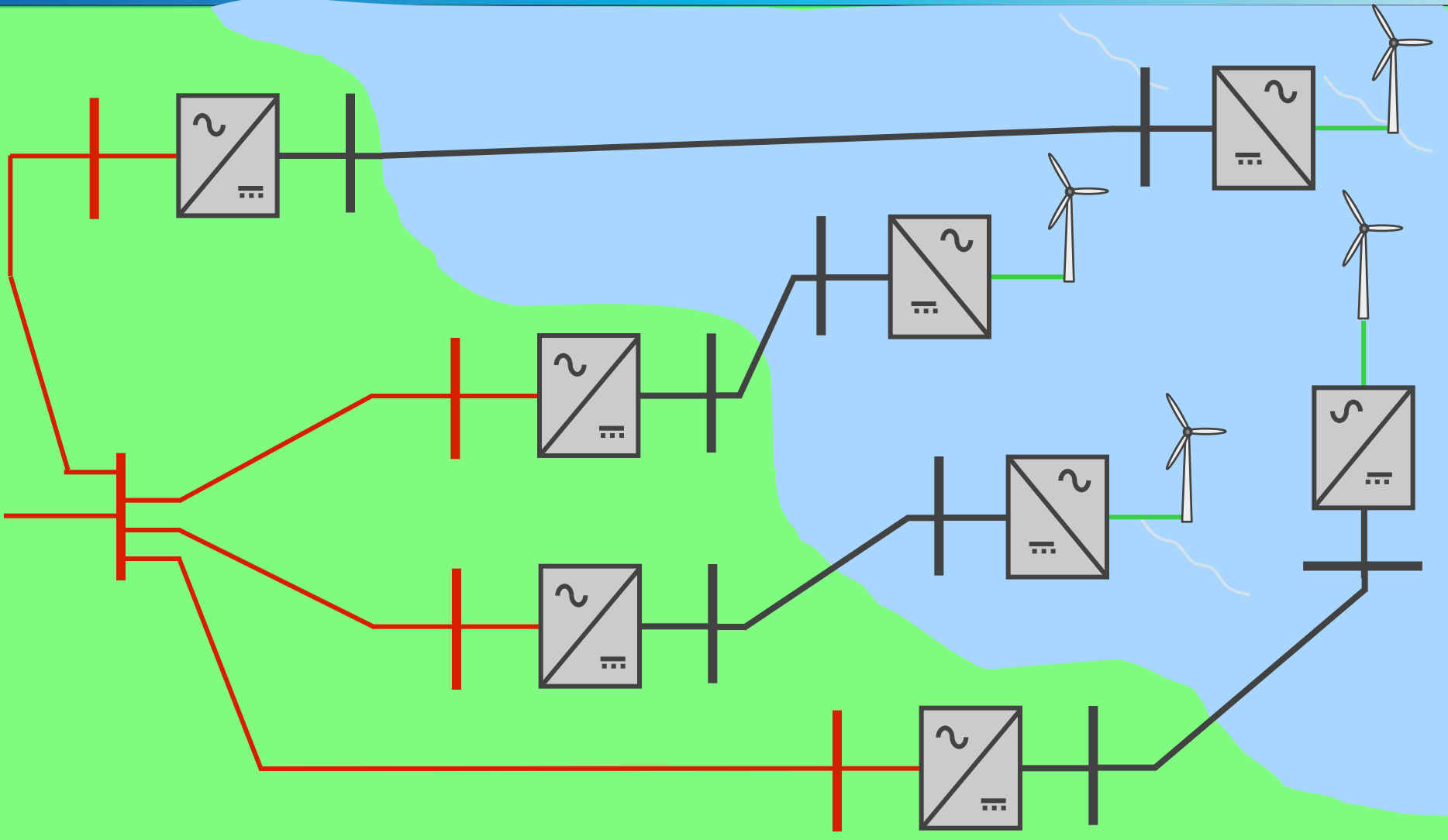

Offshore DC Grid System

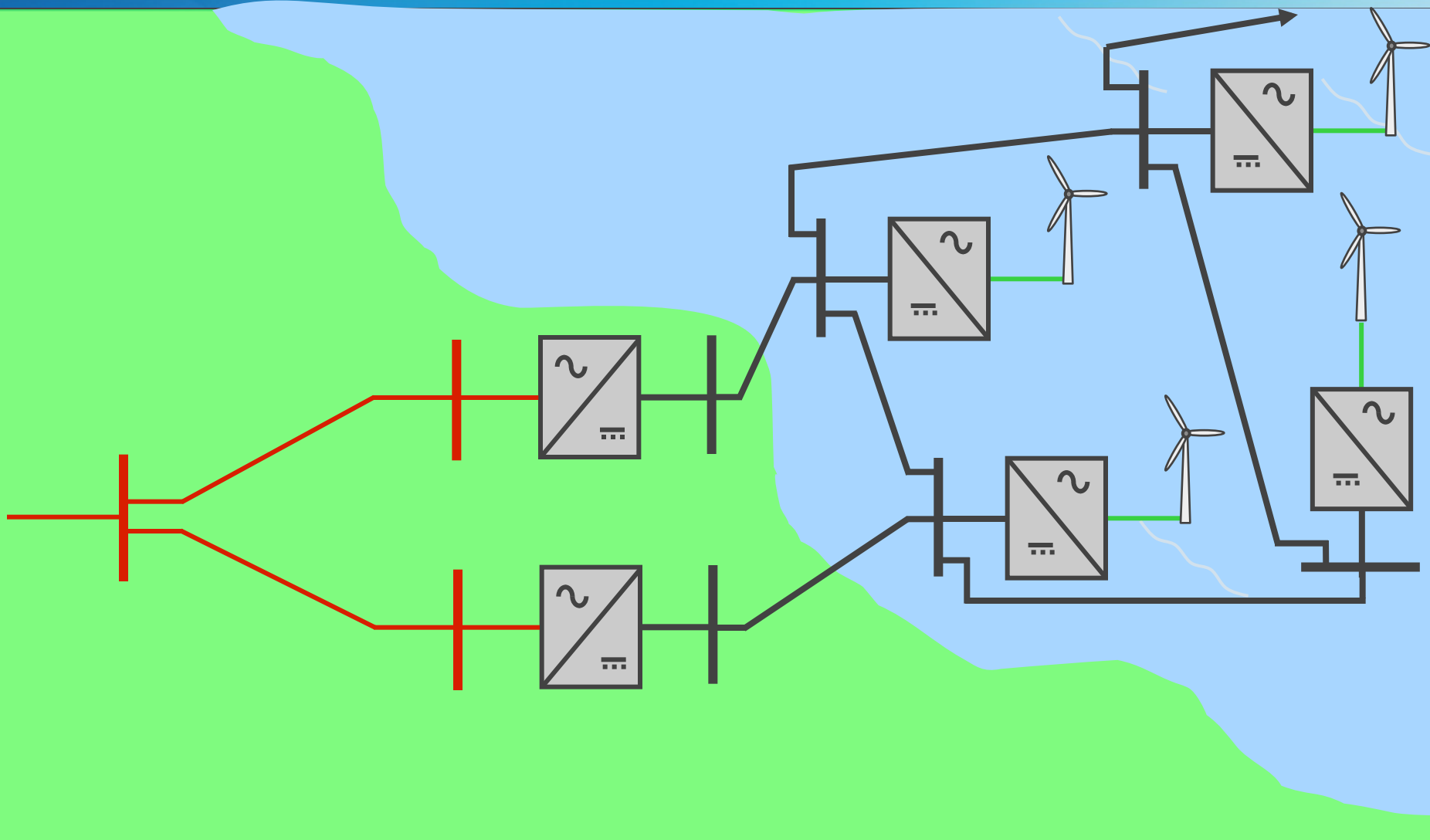

Agenda

How will the Super Grid Evolve?

DC Grid Control

DC Grid Protection

Two-terminal VSC Control

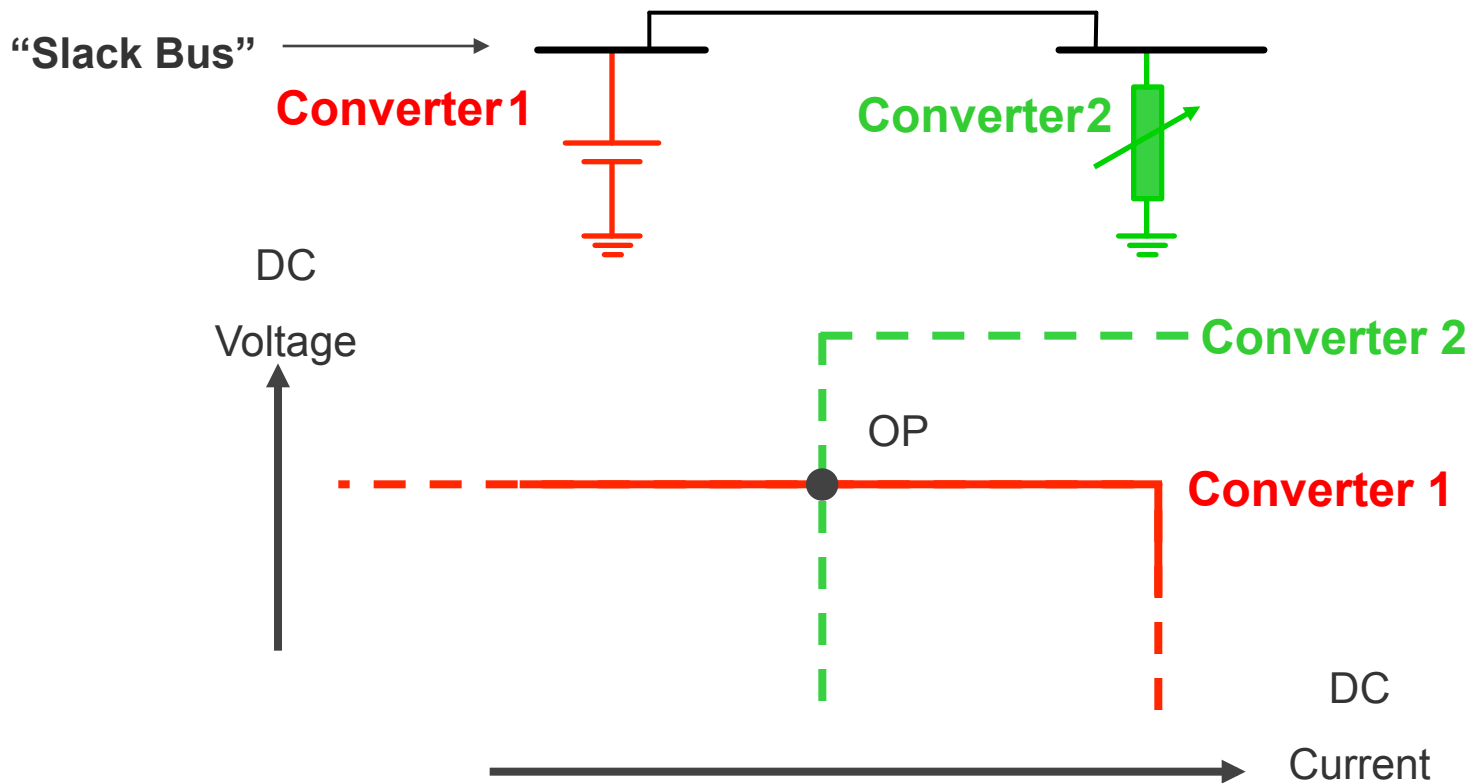

- Basic Converter control of a two-terminal VSC
 - Converter 1 controls DC voltage
 - Converter 2 controls DC current

Multi-terminal VSC Control

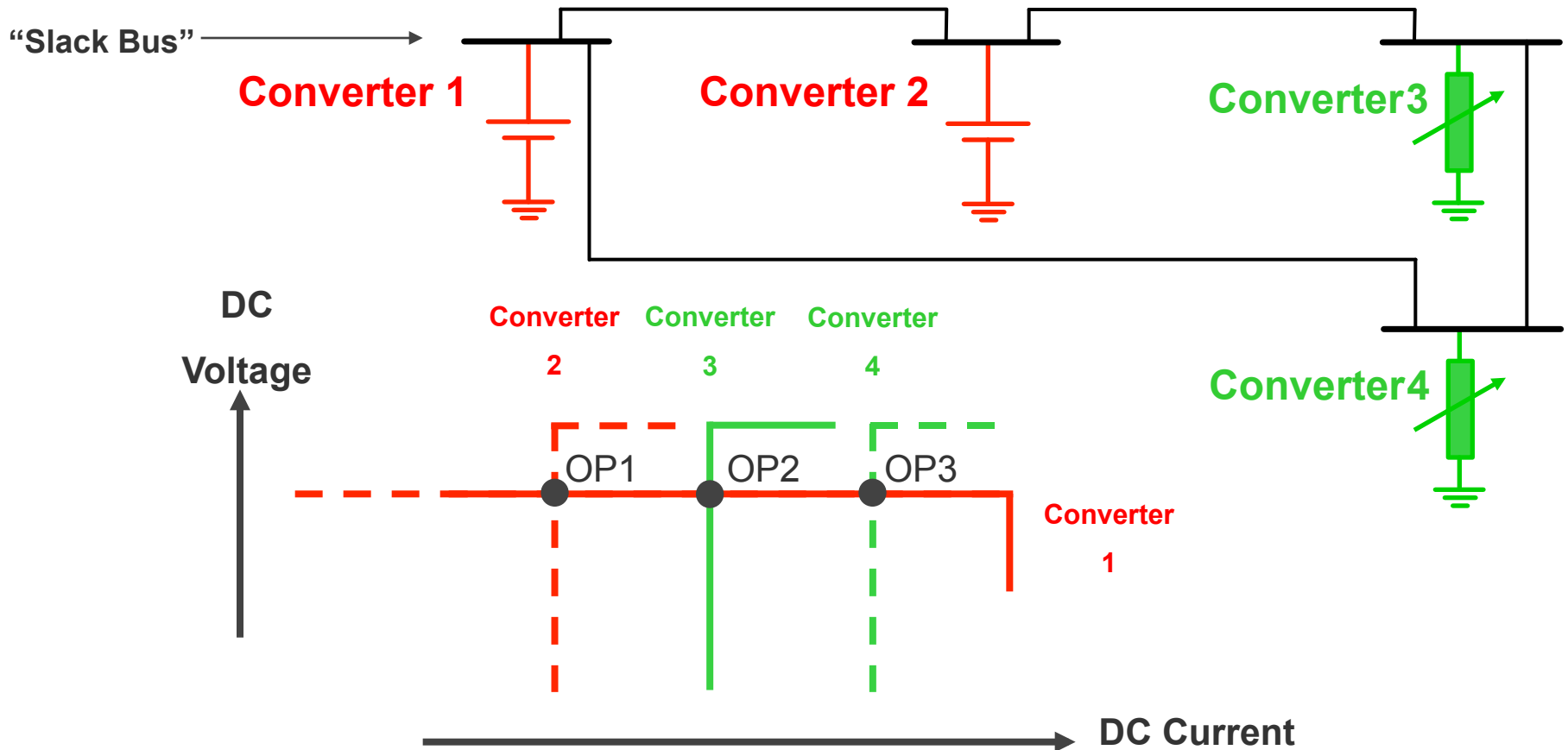

- Will a single utility / system owner be prepared to act as the slack bus for all other interconnected systems?

Alternative VSC Control characteristic

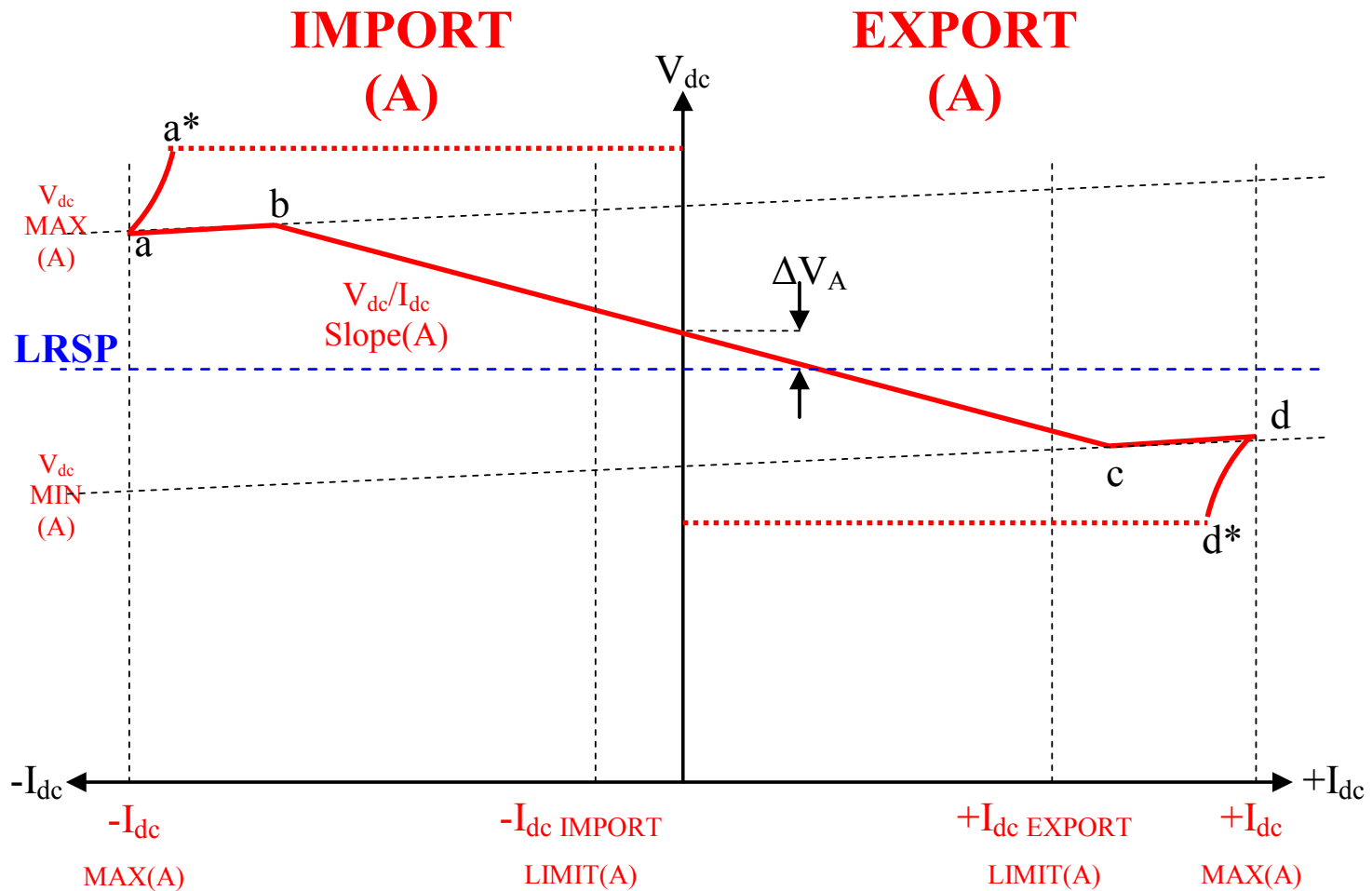

A two-terminal VSC Grid with power flow from terminal A to terminal B

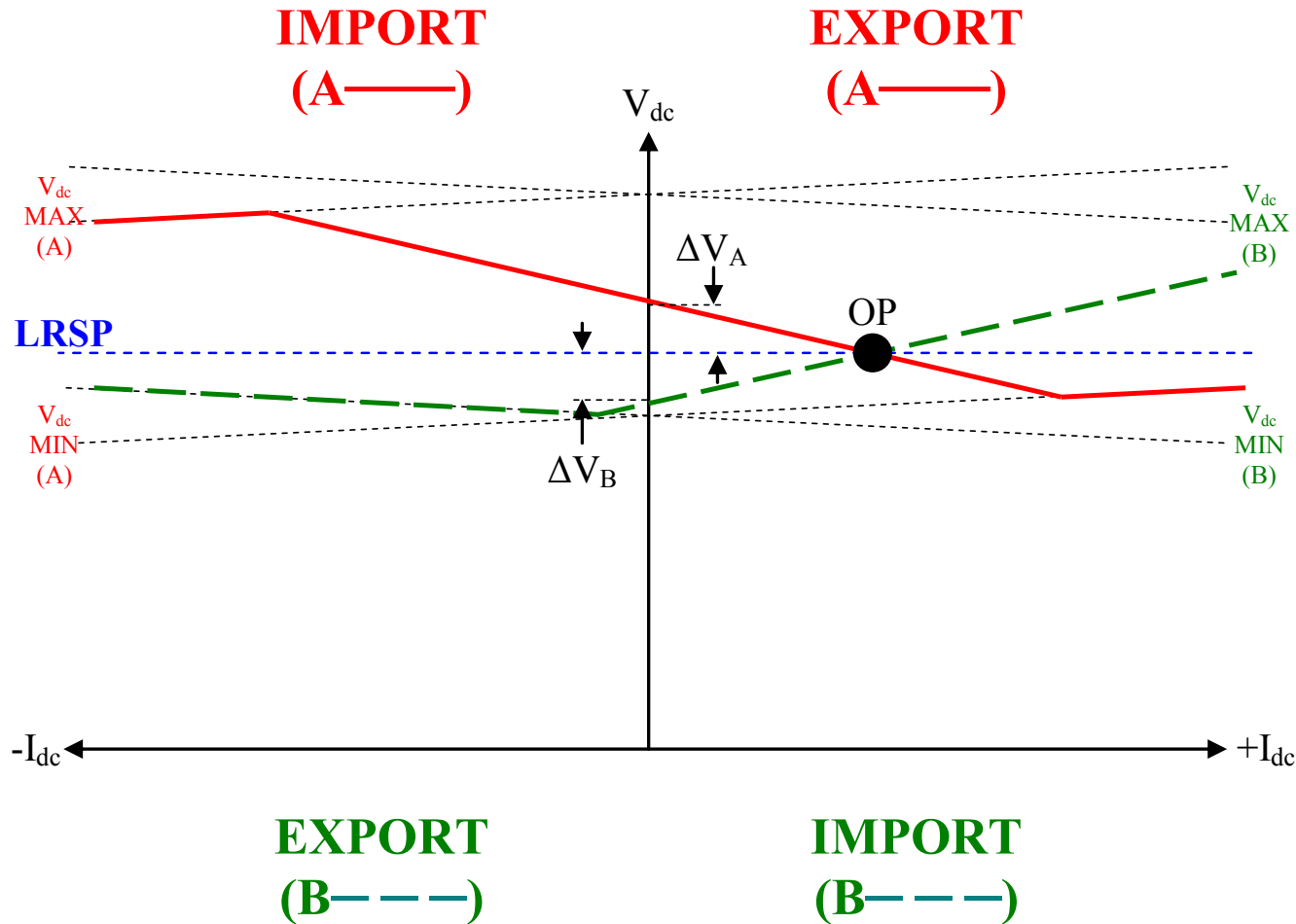

A change in power demand compensated by a new power dispatch

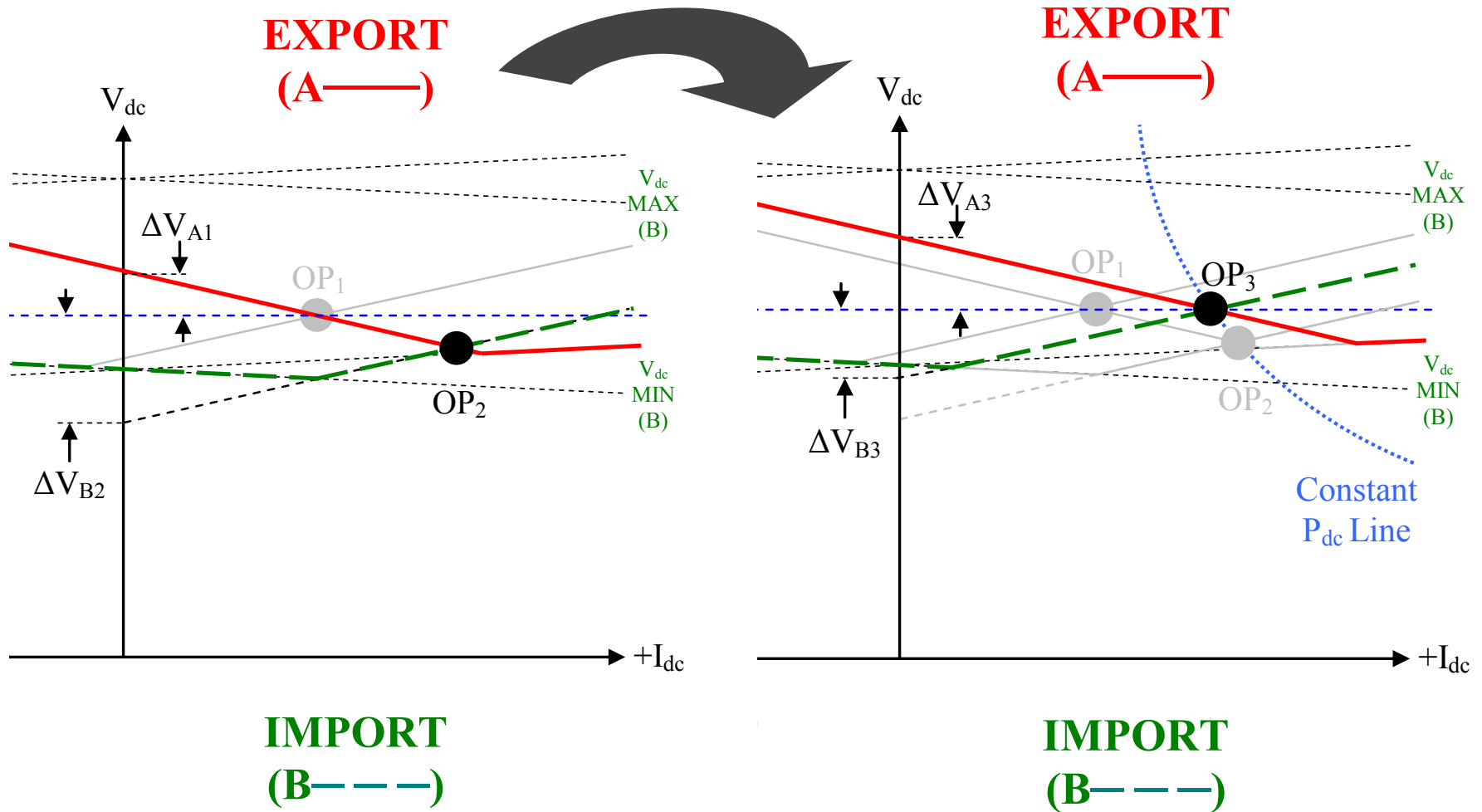

A three-terminal DC grid

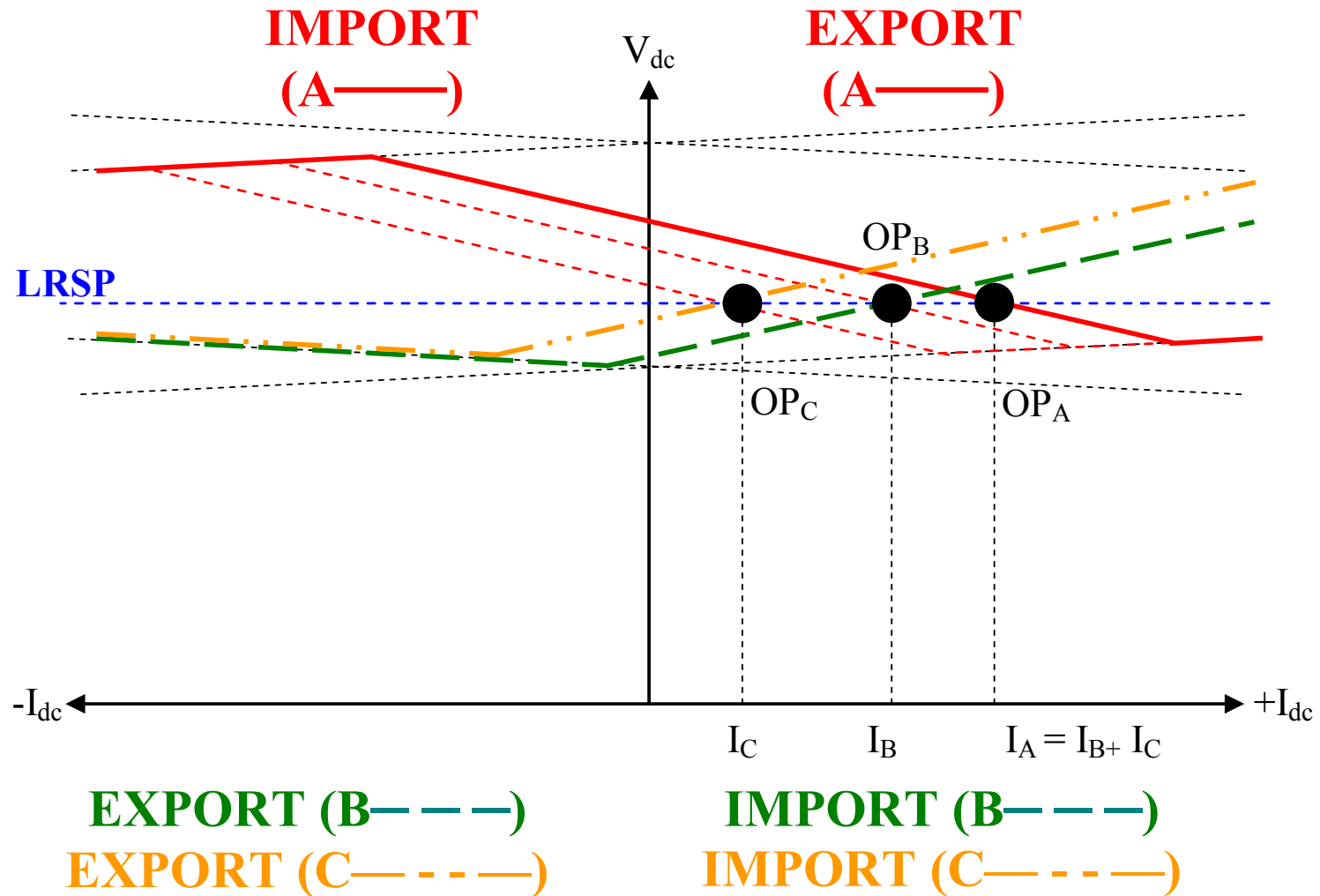

Agenda

How will the Super Grid Evolve?

DC Grid Control

DC Grid Protection

DC Grid protection

Key issues

- **Multi-terminal DC cable systems are “low inertia” systems**
- **A DC fault (voltage on one pole goes to zero) is experienced simultaneously throughout the system**
- **Protection system must discriminate the faulted cable section to allow rapid isolation by switchgear action**
- **Multi-terminal system should return to stable operation, in minimum time with minimum loss of infrastructure**

DC Grid Measurements

 = Current Transducers

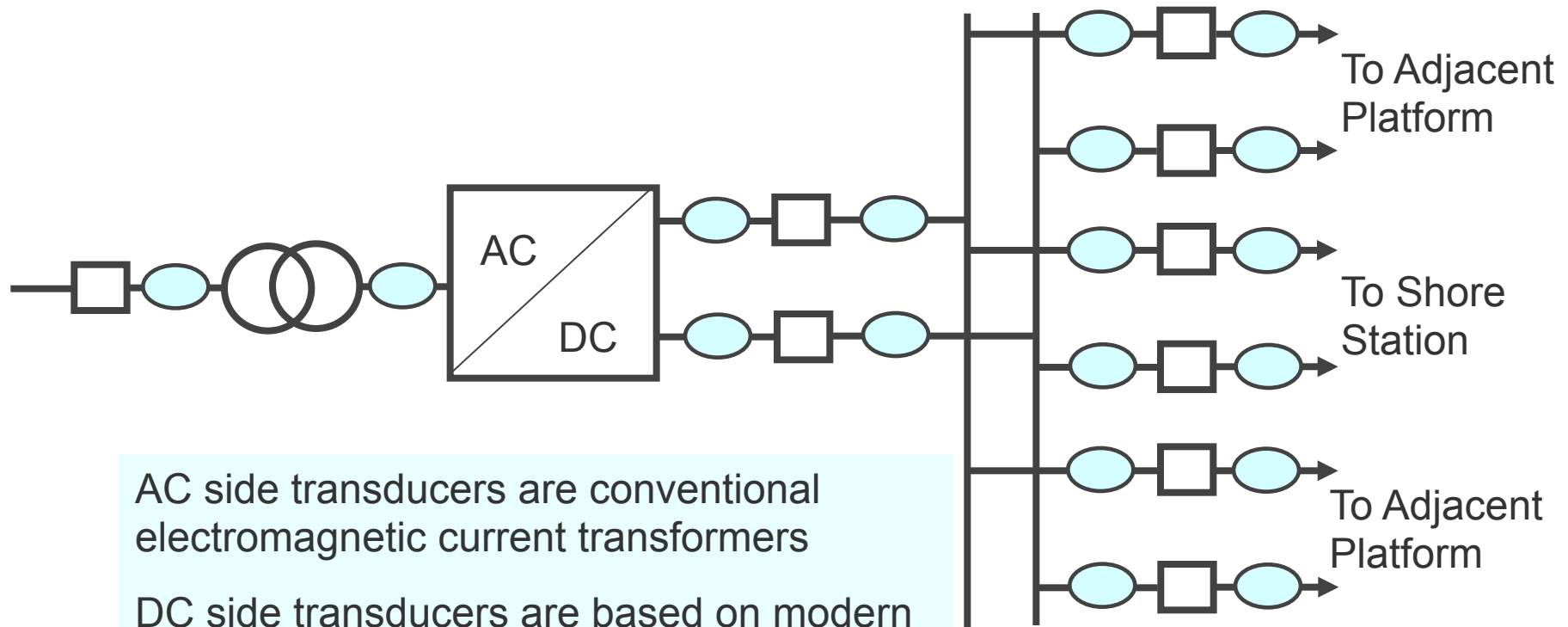

AC side transducers are conventional electromagnetic current transformers

DC side transducers are based on modern fibre optic current measurement techniques

Modular Multi-level Converter : Half link

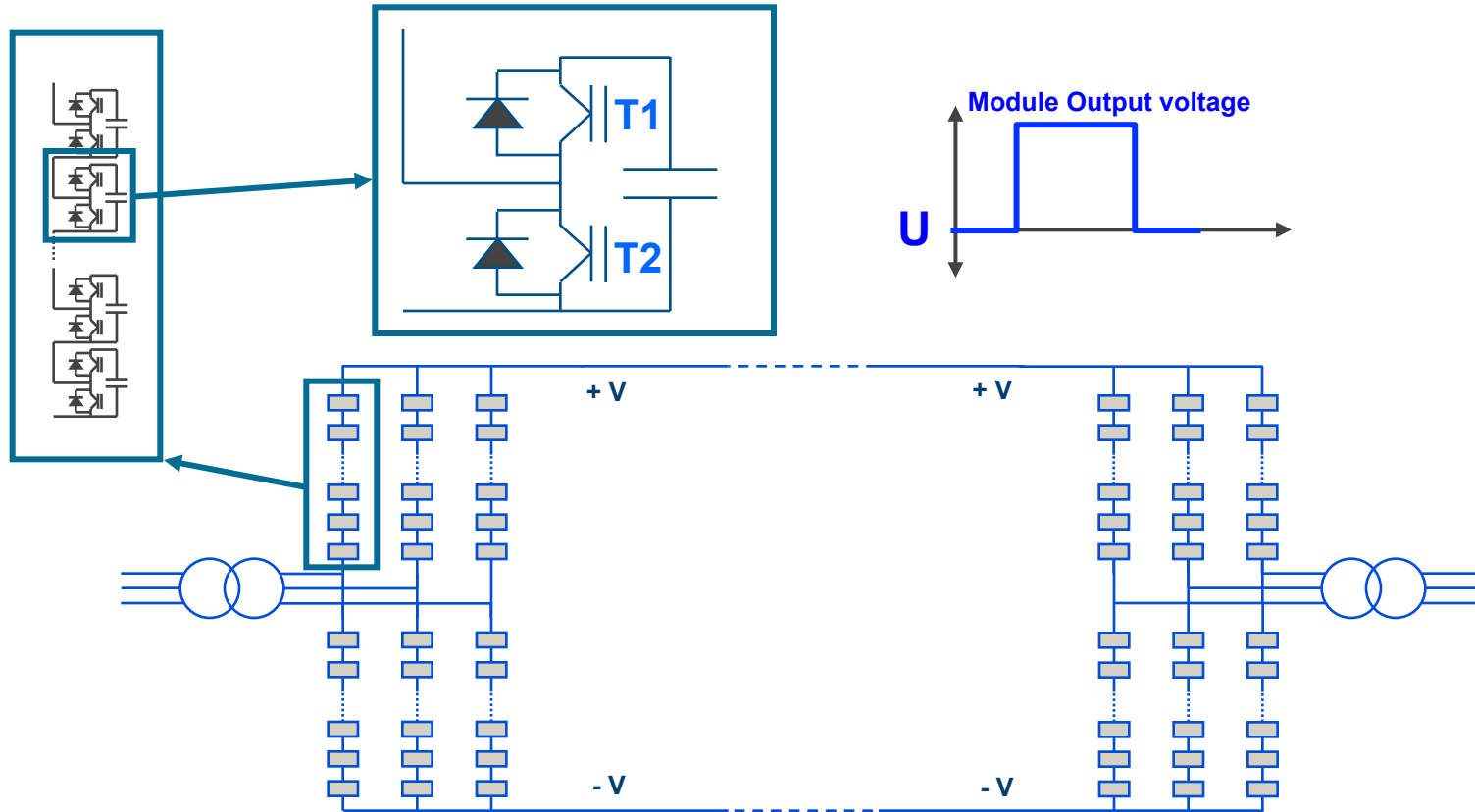

- Lowest component count
- Only one possibility of output voltage polarity

Modular Multi-level Converter : Half link

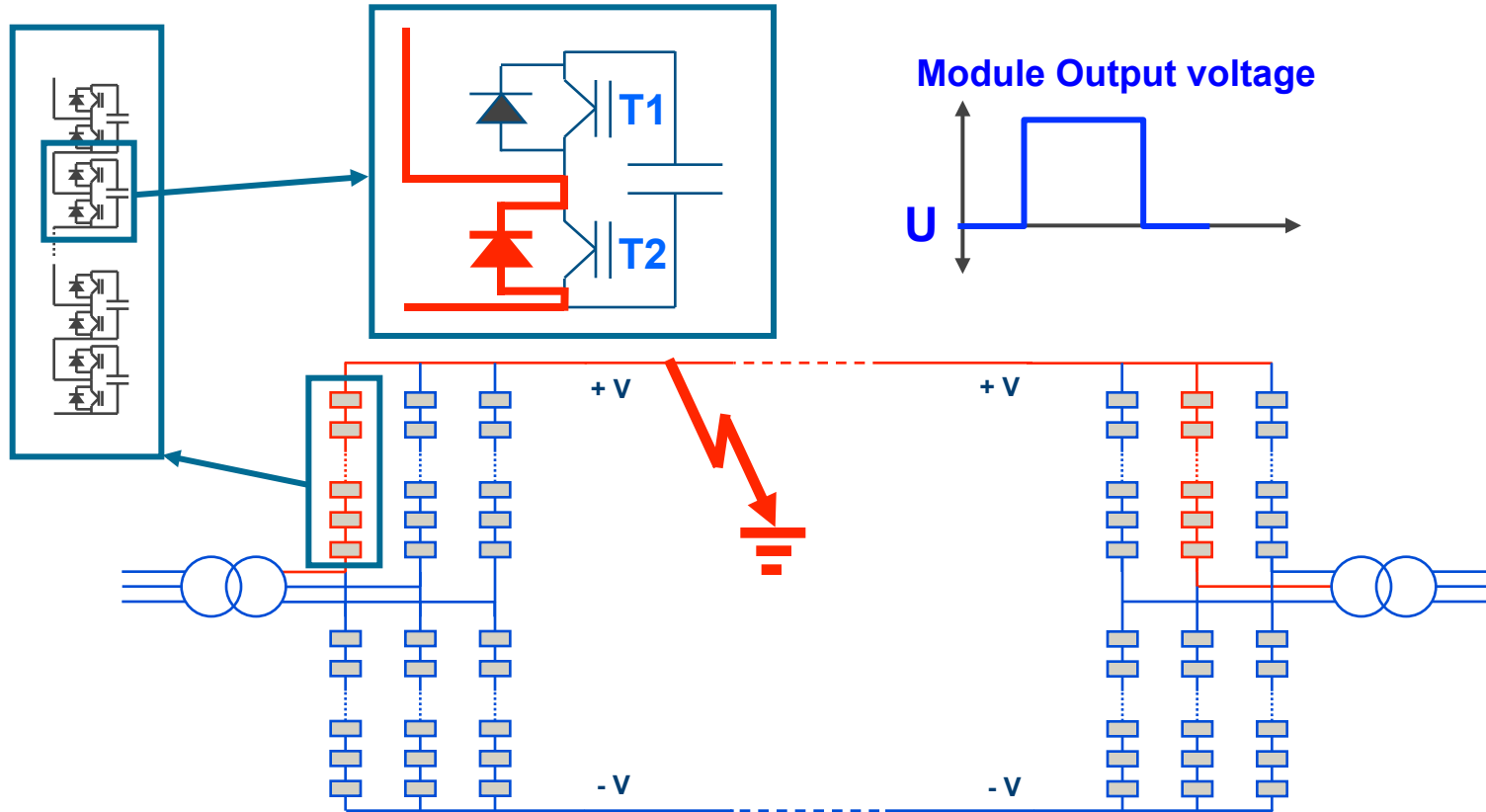

•No capability of suppressing DC-side faults

Option 1 “Half-bridge converters + Disconnects”

 = AC Circuit Breaker

 = Mechanical Disconnect

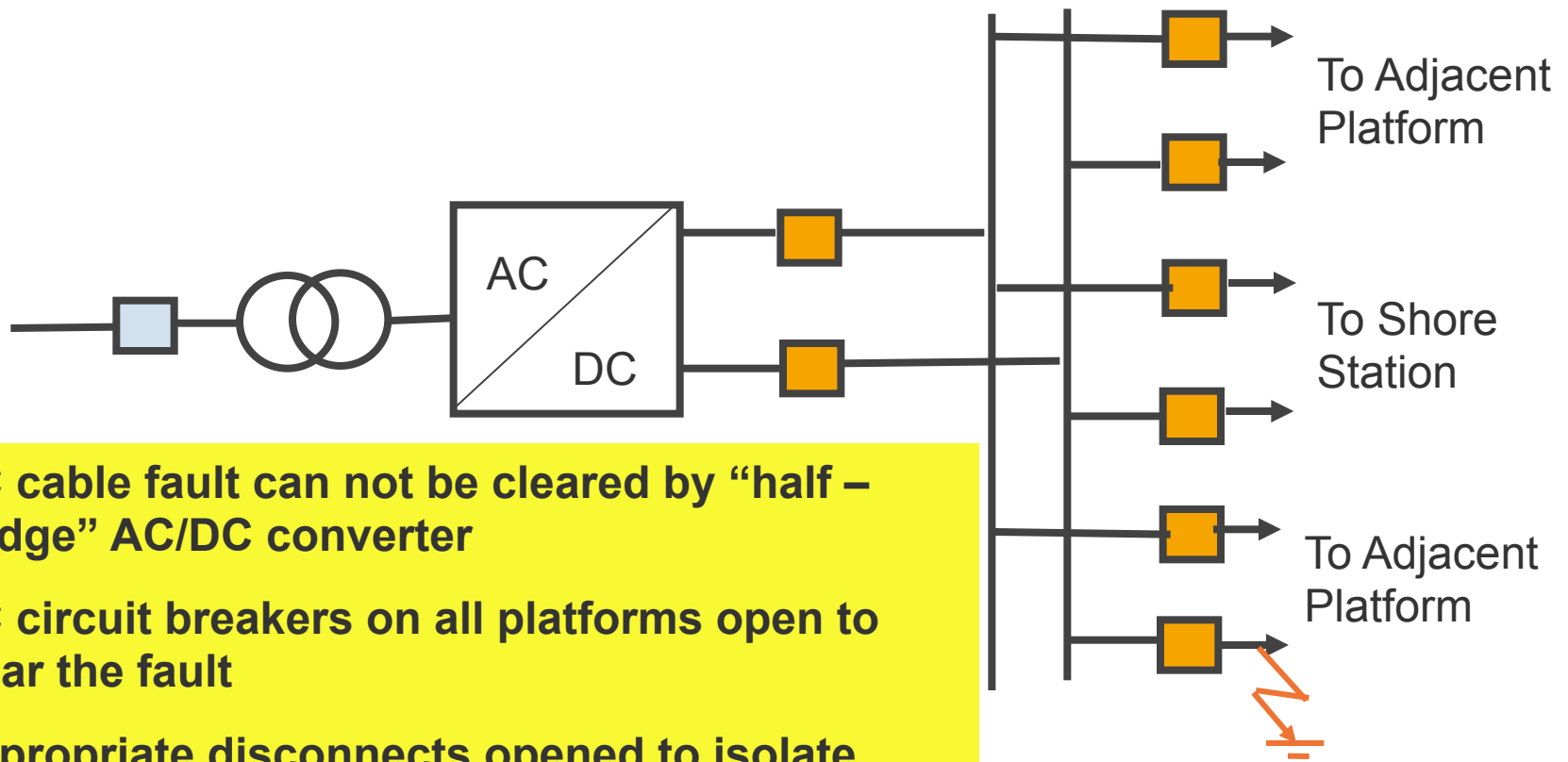

DC cable fault can not be cleared by “half – bridge” AC/DC converter

AC circuit breakers on all platforms open to clear the fault

Appropriate disconnects opened to isolate faulted cable section

Complete multi-terminal scheme is re-started

GRID

ALSTOM

Modular Multi-level Converter : Full link

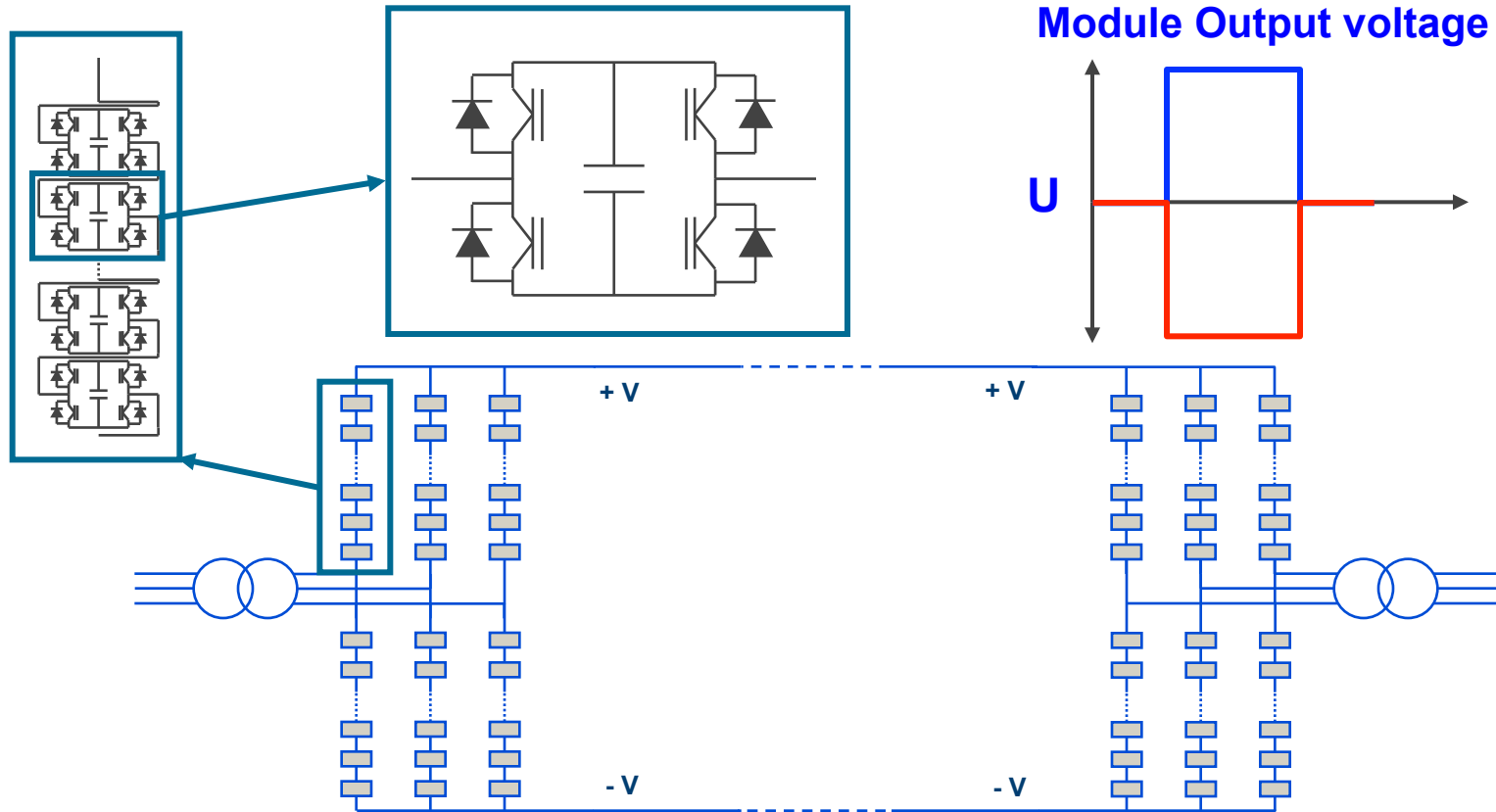

- Same circuit as ALSTOM STATCOM chain circuit
- Output DC voltage can be either polarity
- **Can suppress DC side faults**

Option 2 “Full-bridge” converters + Fast Switches

 = AC Circuit Breaker

 = Fast Isolating Switch

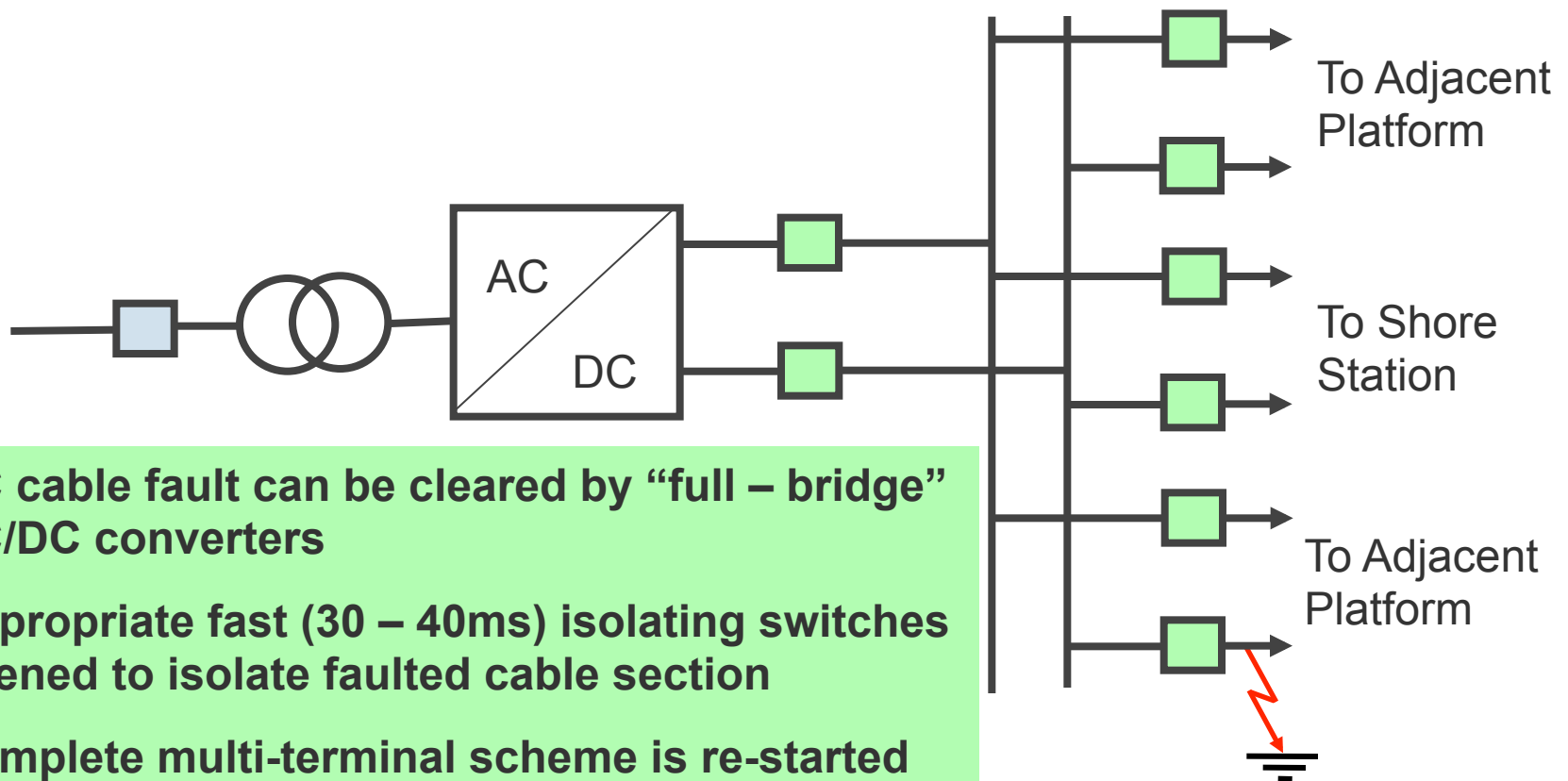

DC cable fault can be cleared by “full – bridge” AC/DC converters

Appropriate fast (30 – 40ms) isolating switches opened to isolate faulted cable section

Complete multi-terminal scheme is re-started in 100 – 200ms

Option 3 “Half-bridge” converters + Circuit Breakers

 = AC Circuit Breaker

 = DC Circuit Breaker

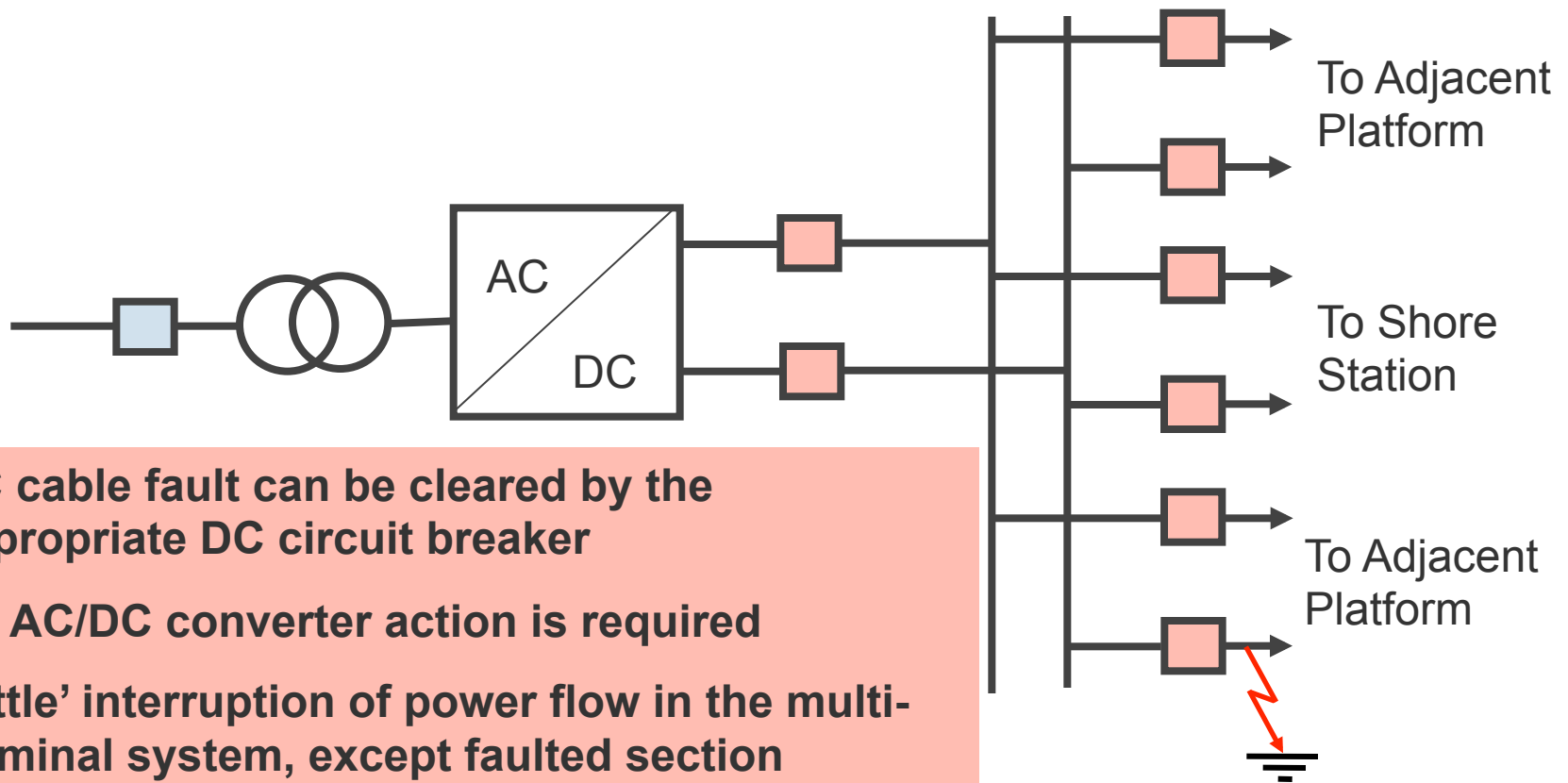

DC cable fault can be cleared by the appropriate DC circuit breaker

No AC/DC converter action is required

‘Little’ interruption of power flow in the multi-terminal system, except faulted section

CIGRE Activities on DC Grids

- **Study Committee B4 (HVDC and power electronics)**
- **Working Group B4 – 52 DC grid feasibility**
 - Convener : Gunner Asplund (Sweden)
 - Initiated mid – 2009
 - Report mid – 2012
 - 5 new daughter WGs now approved
- **B4 – 56 : Grid codes Convener : Phillipe Adam (France)**
- **B4 – 57 : Modelling Convener : Randy Wachal (Canada)**
- **B4 – 58 : Control Convener : Kerstin Linden (Sweden)**
- **B4 – 59 : Protection Convener : Kees Koreman (Netherlands)**
- **B4 – 60 : Reliability Convener : Norman MacLeod (United Kingdom)**

Conclusions

- **A DC grid needs to evolve in the North Sea to limit costs and improve system security**
- **Off-shore wind farms will need to join to interconnectors**
- **We will need a standard DC voltage or DC - DC converters**
- **The concept of a “slack bus”, as per AC systems, does not seem to be a reasonable control system**
- **“Autonomous” control systems can be used to distribute the role of the “slack bus”**
- **All converters would need a similar type of control facility**
 - **Power order**
 - **Load reference set point (LRSP)**
 - **Voltage/current characteristic**
- **Grid protection needs to be fast, but which option**
 - **Simple converters, but trip all AC circuit breakers**
 - **More complex converters and use fast isolating switches**
 - **Simple converters, with DC circuit breakers**

www.alstom.com

ALSTOM